

PULSAFEEDER

A Unit of IDEX Corporation

**Cost Effective
Durable
Efficient**



**Providing Superior Quality In Liquid
Processing Applications Since 1845**

FOSTER[®] Sliding Vane Pump

FEATURES & BENEFITS

- Metal or non-metal vanes
- Optional mechanical seals
- Adjustable packing (other options available)
- Optional adjustable pressure limiting valve
- Optional abrasive-resistant construction
- Efficient vane and liner designs:
 - Lower mechanical friction losses
 - Reduces hydraulic friction and shear losses
 - Reduces liquid slip losses
 - lowers pumping speeds
 - Increases volumetric efficiency
- Energy and Maintenance savings
 - Maintenance-in-place (no special tools)
 - Front pull-out design
 - No need to disconnect pump from piping
 - Easy to install replacement kits (KOPkits)

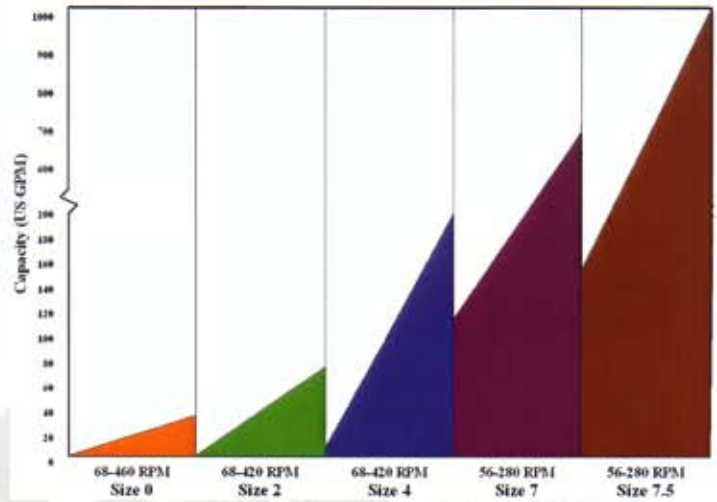

Consult factory for additional flows and sizes.

SPECIFICATIONS & MATERIALS

- Cast or ductile iron housing, liner, vanes, end plates & internal journal bearings
- Cast Iron Flange rating 125 lbs
- Ductile Iron Flange rating 150 lbs
- Flange connections are drilled & tapped (MSS)
- Chrome hardened liner optional
- Carbon steel rotary & shaft
- PTFE packing (or Mechanical seals)
- Epoxy coated finish
- Re-greasable lantern ring design
- Viscosities from 7,500 to 200,000 SSU
- Temperature Ranges (consult factory)
- Flows from 0 to 1000 (US GPM)
- Pressures to 250 PSI

Z = PORT CENTERLINE Consult factory for specifics

SIZE	0	2	4	7	7.5
A	7.5	7.75	10.5	20	20
B	3.25	4	5.62	15	15
D	4.12	7	6.25	11.62	11.62
E	2.88	2.75	3.5	8.12	8.12
F	1.12	1.5	2.19	6.75	6.75
G	0.62	0.62	0.75	1.25	1.25
H	0.56	0.56	0.69	1	1
L	10.12	11.16	15.41	25.91	27.91
M	2	2	4	8	8
N	6	6	9	13.5	13.5
O	15	19	21.5	40.94	40.94
P	8.31	12.31	12.62	21.81	21.81
Q	13.88	15.59	22.06	39.56	43.94
U	1.188	1.375	1.75	3.5	3.5
X	4.5	6	7	10.75	10.75
Z	4.12	7	6.25	12.5	12.5
KEY	0.25	0.31	0.38	0.88	0.88
WT (LB)	95	100	280	1400	1450

All measurements are in inches

APPLICATIONS

- Sugar refining
 - Massecurite (A,B,&C)
 - Magma (A,B,&C)
 - Molasses (A,B,&C)
- Food Products
 - Chocolate formulation
 - Candy and confectionary
 - Corn mash & syrup
 - Jelly, jams, & fillers
 - Ketchups & mustards
- Paints & inks
- Petroleum
- Pulp and Paper
- Pitch (cold tar)
- Textiles
 - Polypropylene, Nylon
 - Glues & Adhesives

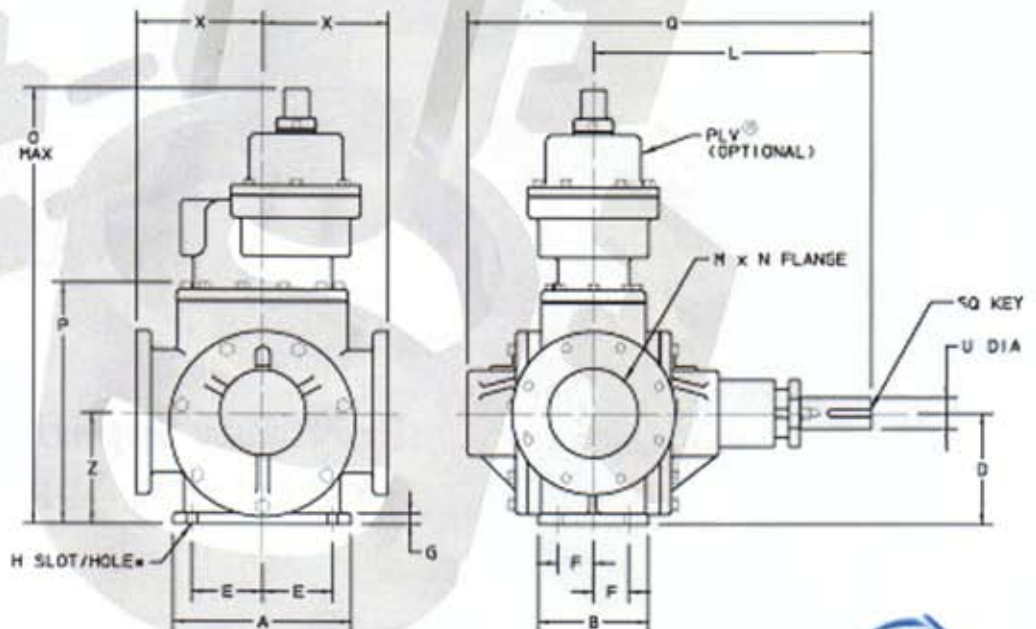

PULSAFEEDER
A Unit of IDEX Corporation

Visit us on the web at www.pulsa.com

