

REF A DRAWING UPDATE
 REVISION UPDATE
 DATE 10/15/97

SECTION/PAGE EFFECTIVE
 SUPERSEDES 04/01/98
 04/04/94

ALL DIMENSIONS ARE IN INCHES
Ischem
SPIN SAFETY
 A Unit of DEK Corporation
 DIMENSIONAL DRAWING
 GM12 PUMP UNMOUNTED
 DWN BY: CLJ
 DATE: 04/04/94
 SD-2773

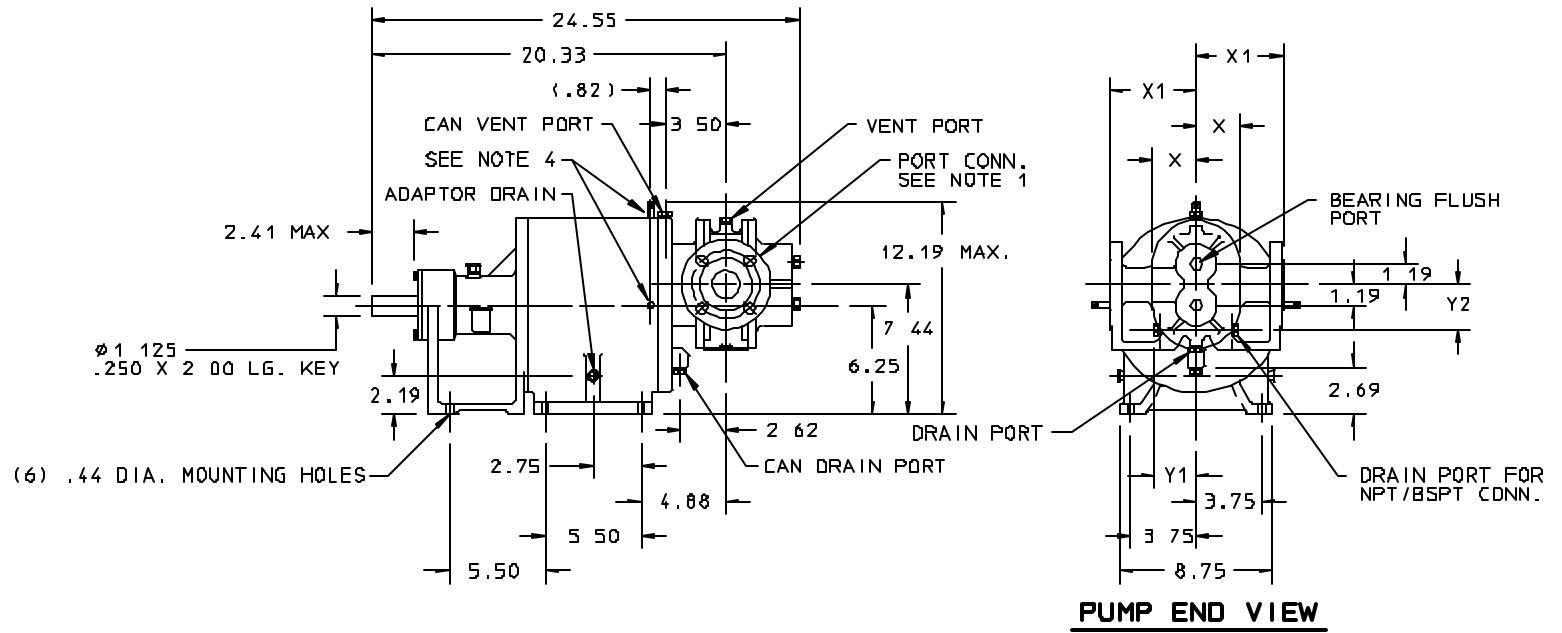

PUMP SERIES	PORT CONNECTION	X	DIMENSIONS		
			X1	Y1	Y2
GM12	1.50 NPT OR BSPT	2.50	-----	2.56	2.44
	1.50-150# RF FLANGE	-----	5.00	-----	-----

NOTE.

- 1.) SUCTION AND DISCHARGE PORTS DEPENDENT ON DIRECTION OF ROTATION
- 2.) ALL STANDARD AND OPTIONAL PIPE PLUGS ARE (1/4" N.P.T.).
- 3.) MOTOR DIMENSIONS VARY BY MANUFACTURER- CONSULT MANUFACTURERS DRAWING FOR SPECIFICS. POWERFRAME WILL ACCOMMODATE MOTOR FRAME SIZES, 182T, 184T, 213T, 215T, 254T AND 256T.
- 4.) (2) 1/8" NPT PIPE CONNECTION PORTS ARE STANDARD WITH DOUBLE CAN OPTION. STANDARD ASSEMBLY IS LEFT/TOP CONNECTION PORT ORIENTATION WHEN VIEWED FROM PUMP END. CUSTOMER TO SPECIFY WHEN RIGHT/TOP CONNECTION PORT ORIENTATION IS REQUIRED